

Product Specification Sheet					
UK Product Code		PANAMA			
Cross ref or supplier code		Panama space saving syphon			

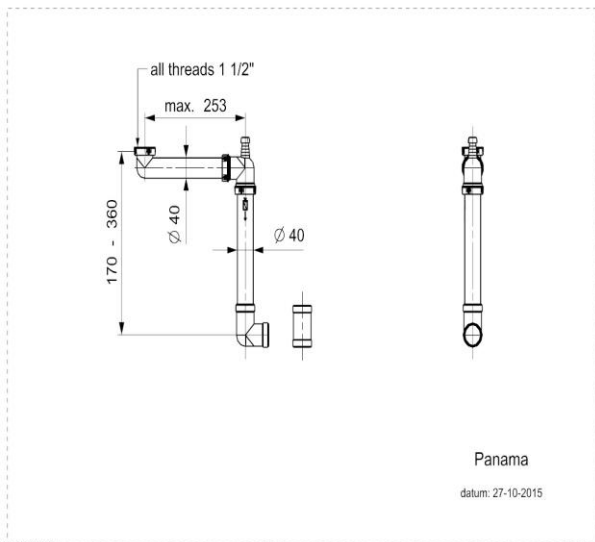

Specification					
Description		Smart space-saving Syphon			
Finish		Plastic			
Warranty		1 year			
Product Weight (kg)		1kg			
Packed Weight (kg)		1kg			
Packed Dimensions (mm)		470mm x 350mm x 10mm			
About the Panama		<p>The Panama is a smart space-saving syphon. The Panama is a complete waste system which saves a lot of space in every cabinet. With an integrated rubber valve that replaces the trap. The water pushes the flexible rubber valve to one side to then be discharged into the drain. Afterwards, the rubber closes the trap into the drain. Afterwards, the rubber closes the trap again, so that the water or smell cannot return. Installation is simple, and connected directly to the drain. The Panama is suitable for both new and already installed sinks</p>			

		<p>The panama has one spigot to connect to Dishwater if customer requires two connections ie to connect to Dishwater and Washing machine they should purchase WM11 SPIGOT. the Panama can be cut down but as long as you don't cut the Membrain in the pipe.</p>
--	--	--